

## Snowmobiles in Antarctica

J. MICHAEL BOYLES<sup>1</sup>, ROBIN A. SCHMUTZLER<sup>2</sup>,  
and PETER D. ROWLEY<sup>2</sup>

**ABSTRACT.** Snowmobiles are the main form of land transportation for field parties in Antarctica. Recently the United States Antarctic program turned almost exclusively to Ski-Doo Alpine 640-ER snowmobiles, the use and maintenance of which require specialized techniques. The first extensive Antarctic field test of these snowmobiles was made during three months of 1977-1978 while engaged in reconnaissance geologic and topographic exploration of the Orville Coast area.

Snowmobiles are used to pull large loads of food and gear on two Nansen sledges. When crossing crevasse fields, they are driven remotely by persons on skis. To do this, modifications are made to the stock throttle to enable the engine both to be set at a constant speed and to be shorted out by pulling on a cord that trails behind the snowmobile; steering is by ropes attached to the front ski of the snowmobile. Proper "night" storage is necessary to ensure easiest starting in the morning and to minimize the effects of storms. A routine of trouble shooting that rapidly isolated and corrected engine problems included first checking spark-plugs or gas-line filters, followed by checking carburetor jet adjustments, drive belt, and oil/gas ratio. We found that Ski-Doos are well suited to Antarctica but would be more useful if carburetor fuel filters were replaced by in-line fuel filters and if snowmobiles were equipped with remote throttle controls, tachometers, speedometers, odometers, and a low-gear option.

### INTRODUCTION

Snowmobiles, or motor toboggans as they are sometimes called, now are the major means of land transportation for remote field parties in Antarctica. In such a field party, snowmobiles are likely to be used nearly every day for exploration of those parts of the ice sheet and mountain masses that lie near permanent or temporary camps and for moving camps to new areas. They have an advantage over other types of vehicles because of their relatively low cost, light weight, and ease of operation and maintenance. During 3 months of the 1977-78 austral summer, the authors used snowmobiles while members of a U.S. Geological Survey expedition. The model we used was a Ski-Doo Alpine 640ER, manufactured by Bombardier, Ltd. (Note: Use of trade and company names in this report is for descriptive purposes only and does not constitute endorsement by the U.S. Geological Survey.) The National Science Foundation, which supports all U.S. research in Antarctica, recently turned to almost exclusive use of this model. Ours was the first extensive field use of this snowmobile in Antarctica. The present report summarizes the results of this field test, and includes techniques also applicable to other types of snowmobiles.

---

<sup>1</sup>Department of Geological Sciences, University of Texas at Austin, Austin, Texas 78712, U.S.A.; work done while employed by U.S. Geological Survey, Box 25046, Federal Center, Denver, Colorado 80225, U.S.A.

<sup>2</sup>U.S. Geological Survey, Box 25046, Federal Center, Denver, Colorado 80225, U.S.A.

The snowmobiles discussed here were used in the Orville Coast region of the southern Antarctic Peninsula. The region is about 30,000 km<sup>2</sup> (12,000 mi<sup>2</sup>) in size, between lat. 74°00'-76°36' S. and long. 64°-73° W., and consists of ice fields and glaciers, through which previously unexplored mountain ranges and nunataks project. Our field party of 7 geologists and 4 topographic engineers lived in tents and explored the area using six new models of the Ski-Doo Alpine 640ER. When used to move camp, each snowmobile towed two Nansen sledges, each sledge carrying food, fuel, and assorted gear weighing upwards of 400 kg (900 lbs.). The total distance covered by these vehicles during the field season was about 9,000 km (5,600 mi), as determined by bicyclewheel odometers. The field party was transported about 2,600 km (1,600 mi) from McMurdo Station, the main U.S. base in Antarctica, to the Orville Coast by U.S. Navy personnel using ski-equipped C-130 Hercules aircraft.

The Orville Coast has a climate and topography that typifies many parts of Antarctica. Elevations in the area range from 150 m (500 ft) to approximately 2,100 m (7,000 ft). Austral summer temperatures range from -30° to +2°C, with an average of approximately -20°C. Humidity is very low, and total snowfall during the summer season was less than 0.5 m (1.5 ft). Winds, sometimes with blowing snow, occur most days, commonly at speeds of more than 50 knots. Ground surfaces consist of hard packed snow that is rippled by sastrugi, most of which are less than 0.5 m (1.5 ft) high. Soft snow, commonly less than 5 cm (2 in) thick, coats most surfaces. Blue ice is occasionally encountered.

The climate, topography, and crevasse dangers in Antarctica require specialized snowmobile techniques not required in other regions. The remoteness of field parties, the high cost of logistics, and the sole dependence for transportation on this type of vehicle require careful attention to their correct use. Techniques used by field parties have evolved over many years of field work by the U.S. Geological Survey and other organizations. Many varieties of snowmobiles have been used in the past; their operation has been described by Swithinbank (1962), Soholt and Craddock (1964), and Boyer *et al.* (1976).

#### FIELD PREPARATION AND GENERAL SNOWMOBILE USE

Extensive preparations were necessary before embarking for Antarctica. Because the senior author is not a mechanic, he attended a very valuable two-day Ski-Doo mechanics course, given by Bombardier, Ltd. for Holmes and Narver, Inc. As there was to be only one resupply flight, a wide variety of tools and spare parts had to be assembled; the items are listed in Tables 1a, 1b, and 1c.

Before being shipped to McMurdo Station, five of the six snowmobiles were fitted with a lower gear ratio, available from Bombardier. Vehicles so equipped can pull larger loads and achieve about 10 to 20% better gas economy than snowmobiles with standard gear ratio. In McMurdo, all snowmobiles were checked, serviced, broken in, and modified for Antarctic use.

In the Orville Coast, each two-man team had a snowmobile and an accompanying train of two Nansen sledges. Generally, one man sat on the snowmobile seat while the other skied behind, pulled by a rope attached to the rear sledge. Even though the Ski-Doo 640ER snowmobile may attain speeds of more than 50 km/hr (30 mph), such speeds are not practicable in Antarctica because of the hard irregular sastrugi-covered surfaces and the heavy cargo loads. Travel speeds were generally 10-11.5 km/hr with fuel consumption while loaded averaging 3.0-3.5 km/l (7-8 mpg).

Regular gas (about 95 octane) proved satisfactory in the snowmobiles. It was mixed with the proper amount of Blizzard oil (50 parts gas to 1 part oil) while transferring gas from fuel drums to jerry cans. Fuel drums should not be drained entirely, for all contain impurities that accumulate in the bottom. Snowmobile gas tanks were filled from the jerry cans. During filling, two layers of felt, stretched across the funnel to the gas tank, absorbed water and filtered solids in the gasoline. When there were significant amounts of water in the gas, gas-line antifreeze (isopropanol) was added to the gas at half the recommended strength, 4.7 cm<sup>3</sup>/l of gasoline (6 oz per 10 gals). This was not done often, however, because it makes the engine run hotter and there is a greater chance of seizing the engine.

Most cowlings were removed from Ski-Doos before the start of the season. This made for cooler running engines and allowed the driver to manually engage gears and watch for problems in the engine area. Without cowlings there was little packing of windblown snow around the engine during storms. It was also noted that if the plastic dashboard area were cut away, there was less accumulation of snow there, and the carburetor and ignition areas were more accessible to repairs.

#### REMOTE OPERATION OF SNOWMOBILES

Crevasses are present virtually everywhere in the field area. Most crevasses are bridged by windblown snow and are commonly concealed. These bridges are of uncertain strength. Danger posed by crevasses makes it prudent that snowmobiles sometimes be driven remotely by a person on skis (Fig. 1).

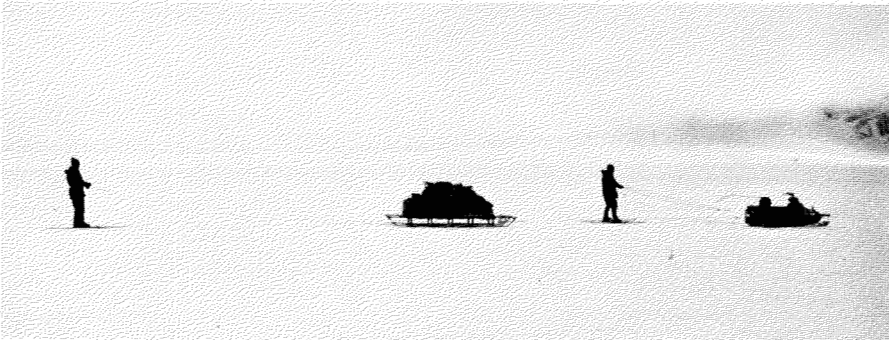

FIG. 1. Photograph showing remote operation of snowmobile.

Hence, if a snowmobile drops into a crevasse the driver can release the rope. Furthermore, skiing behind snowmobiles requires exertion, which keeps the skier warm.

Four snowmobiles were modified for remote operation. For this, three problems had to be solved: 1) steering; 2) throttle control; and 3) "killing" the engine. To steer, a rope was attached to the front ski of the snowmobile using a 2:1 mechanical advantage with two pulleys (Fig. 2). To prevent tangling in

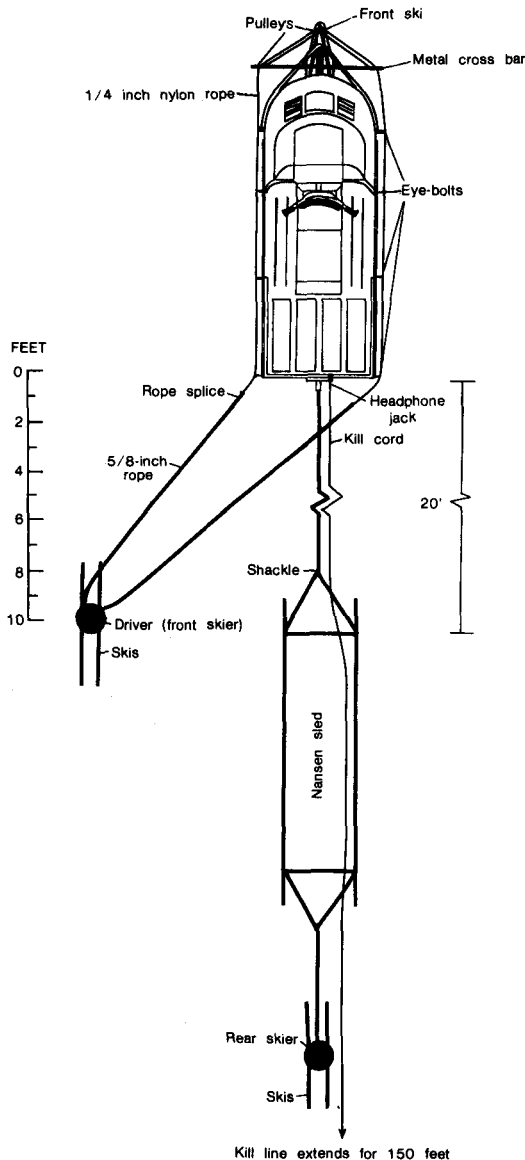

FIG. 2. Plan view of remote steering mechanism.

the track, the rope was guided along the side of the snowmobile by a series of eyebolts. To achieve an efficient pulling angle, a 1-m-long steel bar was bolted to the front bumper.

To control and adjust vehicle speed, the Ski-Doo handlebar throttle was modified. The stock throttle is activated by depressing with the thumb while gripping the handle with the other fingers. When the spring-loaded throttle is released, it pops up and the snowmobile coasts to a stop. Modification (Fig. 3)

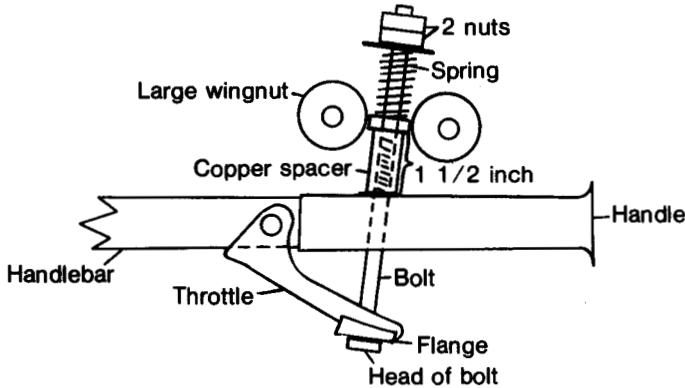

FIG. 3. Snowmobile handlebar throttle showing modifications for remote driving. The copper spacer keeps the threaded part of the bolt out of the handlebar.

to allow the throttle to be set at a constant speed involved drilling a hole through the throttle and handle, through which a 1/4-inch bolt was inserted. This bolt could be screwed down by use of large handmade wingnuts (large enough to be turned by a person wearing mittens). Because this bolt tended to loosen while driving, a 2.5 cm (1-in) long compression spring, placed between the wingnut and a washer attached by two nuts, was used to provide tension. A curved flange, welded to the head of the bolt, was added to prevent the bolt from loosening by driving vibration. Possibly a better alternative would be to use a small outboard-motor-type throttle (available from Seagull Ltd., Longfleet, Poole, Dorset, England) hooked to the dashboard or to the handlebars. This mechanism, in wide use by the British Antarctic Survey, has the advantage of preventing cold thumbs, but the disadvantage of increasing the danger of a run away Ski-Doo.

A system to kill the engine remotely is necessary in case the driver, on skis, falls. The kill switch works by shorting out the current to the spark plugs. To do this, a headphone jack was connected to the wires of the stock kill switch in such a way that when the plug is pulled from the jack, contact is made (Fig. 2), and the current is shorted out (Fig. 4). The plug was attached to parachute cord about 50 m long, which extended out past the rear of the snowmobile and through the lashing ropes on the Nansen sledges. From there it was dragged along on the snow surface behind the rear Nansen. A piece of cloth was attached to the end of the cord to make it easier to grab. If proper tension is kept on the cord, it can be kept out of the snowmobile track and sledge runners.

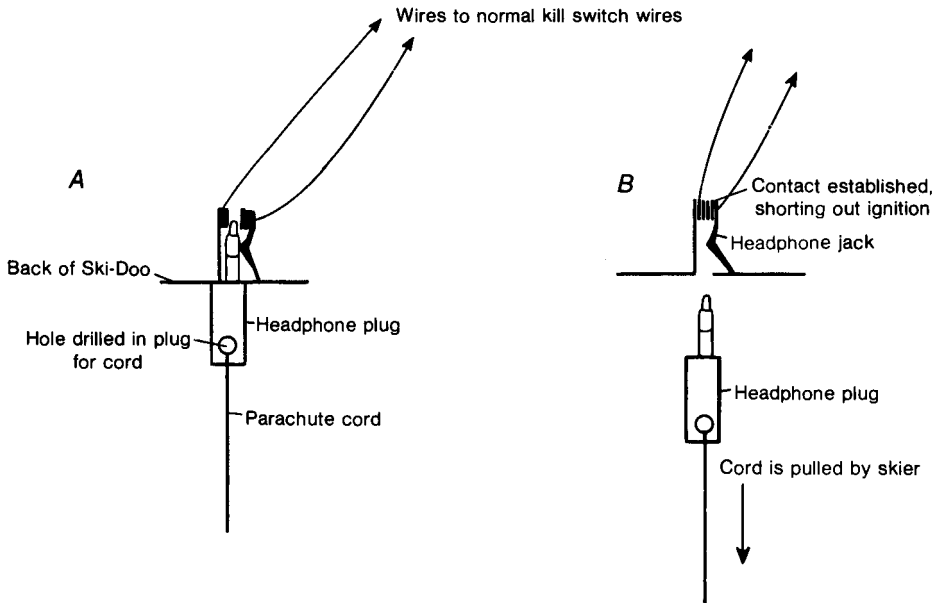

FIG. 4. Mechanism for remote throttle kill, showing configuration (A), during driving, and (B), for stopping.

With these devices installed, the driver starts remote operation while sitting side-saddle, with skis on, on the seat of the snowmobile. He selects the proper speed by depressing the throttle by screwing down the wingnut. The steering rope trails in the snow behind the moving snowmobile. When the snowmobile has attained the proper speed, the driver stands on his skis and as the snowmobile moves past him he leans over and picks up the steering rope. He then is pulled behind and to the side of the snowmobile. A left turn requires a gentle pull on the steering rope by the left hand. To change the speed of the snowmobile, the driver can easily pull himself up to the snowmobile seat with the steering rope and adjust the throttle.

#### MAINTENANCE

Each snowmobile was equipped with a jerry can of extra fuel and a 1 x 1/4 x 1/4 m metal box containing tools and spare parts for those normal problems we expected (Table 1a). The jerry can and sledge box were attached to the rear of the Ski-Doo with rubber straps. Also, the geologic and topographic parties each hauled a 1 x 1/2 x 1/2 m metal sledge box containing specialized tools and additional spare parts (Tables 1b and 1c).

Because our snowmobiles were new, they had to be "broken in" before being flown to the field area. Break-in required running each Ski-Doo a total of at least 10 hrs, after which they were checked. This 10-hour check also was part of our preventive maintenance schedule, and was performed several times a month (Table 2).

TABLE 1a. Equipment list for toolbox on each Ski-Doo.

- 
1. Ski-Doo manual (provided with the snowmobile)
  2. Ski-Doo tool kit (provided with the snowmobile)
  3. Pliers
  4. Adjustable wrench (8")
  5. Large screwdriver
  6. 10 feet of starter rope
  7. 10 feet of wire (used in replacing starter rope)
  8. Gas line filter (1 per machine per week of operation)
  9. Spark plugs (one set, with proper gap setting, per machine per week)
  10. 2 cans "Heet" (isopropanol or other gas-line antifreeze)
  11. Can of Ski-Doo oil
  12. Butane torch kit
  13. Remote throttle control
  14. Rope for remote steering
  15. Drive belt
  16. 3 shackles (used in pulling Nansen sleds)
  17. Rags
  18. Funnel
  19. Pour spout for 5-gallon gas can
  20. Felt (for filtering gasoline)
- 

TABLE 1b. Equipment list for large tool box (one per party).

- 
1. Ski-Doo shop manual
  2. Conventional socket set
  3. Metric socket set
  4. Allen wrenches
  5. Files
  6. Locking pliers
  7. Pliers
  8. Screwdrivers
  9. Flywheel puller\*
  10. Fan belt tool\*
  11. Arc-joint pliers
  12. Chisels
  13. Adjustable wrench
  14. Bung Wrench
  15. Valves for 55-gallon drums
  16. Small crowbar
  17. Claw hammer
  18. Nails

19. Screws, nuts, and bolts
  20. Rubber cord and hooks
  21. Ski-Doo Blizzard oil
  22. "Heet" (isopropanol)
  23. "Come-a-long" jack
  24. Wire, assorted gauges
  25. Spare pulleys, eye bolts, throttle control, and kill switches for remote control setup
  26. Penetrating oil
  27. Light-weight machine oil
  28. Ski-Wax (for Nansen runners)
  29. Hand cleaner
  30. Hack saw
  31. Ball-peen hammer
  32. Needle-nose pliers
  33. Tape measure
  34. Wrench set, open and closed ends
  35. Feeler guage
  36. Sandpaper and emery cloth
- 

\*Special Bombardier tools

TABEL 1c. List of spare parts for each field party.

---

1. Fuel line, 20 ft
2. Spark plugs, 80
3. Fuel filters, 40
4. Drive chain with extra master links
5. Bogie wheel assemblies, 4
6. Points and condenser, 2 sets
7. Spark-plug wires and caps, 2 sets
8. Drive belt, 10
9. Fan belt
10. Pull-starter assemblies, consisting of 1 complete unit, 3 springs, 2 kits, and 50 ft of replacement rope
11. Ignition switch with keys
12. Electric starter
13. Electrolite
14. Gas cap
15. 14-amp fuses for electric starter, 4
16. Choke cable
17. Throttle cable
18. Drive shaft



TABLE 2. Ten-hour check and preventive maintenance checklist.

- 
1. Inspect bogies for broken springs daily, and grease bogie shafts (10-hr check only)
  2. Inspect and adjust tracks
  3. Grease driven-pulley shaft once weekly (one drop inside and one drop outside the driven pulley; do not overgrease)
  4. Check tool kit; make sure it is complete and any used items replaced
  5. Check gas-line filter
  6. Replace chain-case oil during 10 hr check; thereafter only check level, unless oil is dirty.
  7. Torque-head bolts (10 hr check only)
  8. Check chain tension
  9. Check fan-belt tension
  10. Tighten bolts; be sure to tighten the bogie bolts
  11. Check battery; fill with electrolyte only (do not put water into batteries, as it will freeze)
  12. Check plugs (see owners manual)
- 

#### PREPARATION FOR STORMS AND NIGHTS

Proper "night" storage is important to insure easier starting in the morning and to prevent mechanical problems should a storm move in. The following procedures, performed at the end of the day, will assure easiest starting and minimize storm effects: 1) always kill the engine by pulling the choke out, then turn off the ignition key; 2) do not park snowmobiles in the wind shadow of another object; 3) face snowmobiles into the wind; 4) remove cowling, if not already done; 5) open access door in dashboard; 6) stuff air intakes with rags; and 7) fill gas tanks to prevent overnight condensation of moisture in the gas tank. Sometimes snowmobiles were driven rapidly at the end of the day to burn off carbon that accumulated during slow travel under heavy loads.

Proper digging-out and starting procedures after a storm also are important because improper procedures can cause a burned drive belt, ruined clutch, or other problems. The following steps were used: 1) remove most snow from under the dashboard, being careful not to turn the low-speed jet screw; 2) remove the pull starter and fan guard and remove snow from these areas (minute amounts of snow or ice on the points caused most starting problems after a storm) then replace pull starter; 3) check the throttle and choke for freedom of movement; 4) remove snow from the drive belt area; be sure the driven pulley can operate freely; 5) roll the snowmobile on its side and remove snow from the tracks then roll the snowmobile upright; 6) start the engine; if using the pull starter, pull gently the first few times to allow the starter assembly to loosen up; 7) lift the rear of the snowmobile, then place in reverse gear and spin the track for 15-20 seconds to completely remove snow (when changing gears, stop the spinning clutch with the handbrake — otherwise the transmission can be ruined); and 8) drive around for several

minutes to warm the engine and burn off any moisture that may have entered through the carburetor.

The snowmobile engine may run roughly after a storm. This will most likely be due to ice in and on the carburetor. Ice on the carburetor blocks the atmospheric ports, preventing proper running. The best remedy is to run the snowmobile for several minutes, then kill the engine and close the choke. Repeat this procedure several times if necessary. This traps heat from the engine and warms the carburetor.

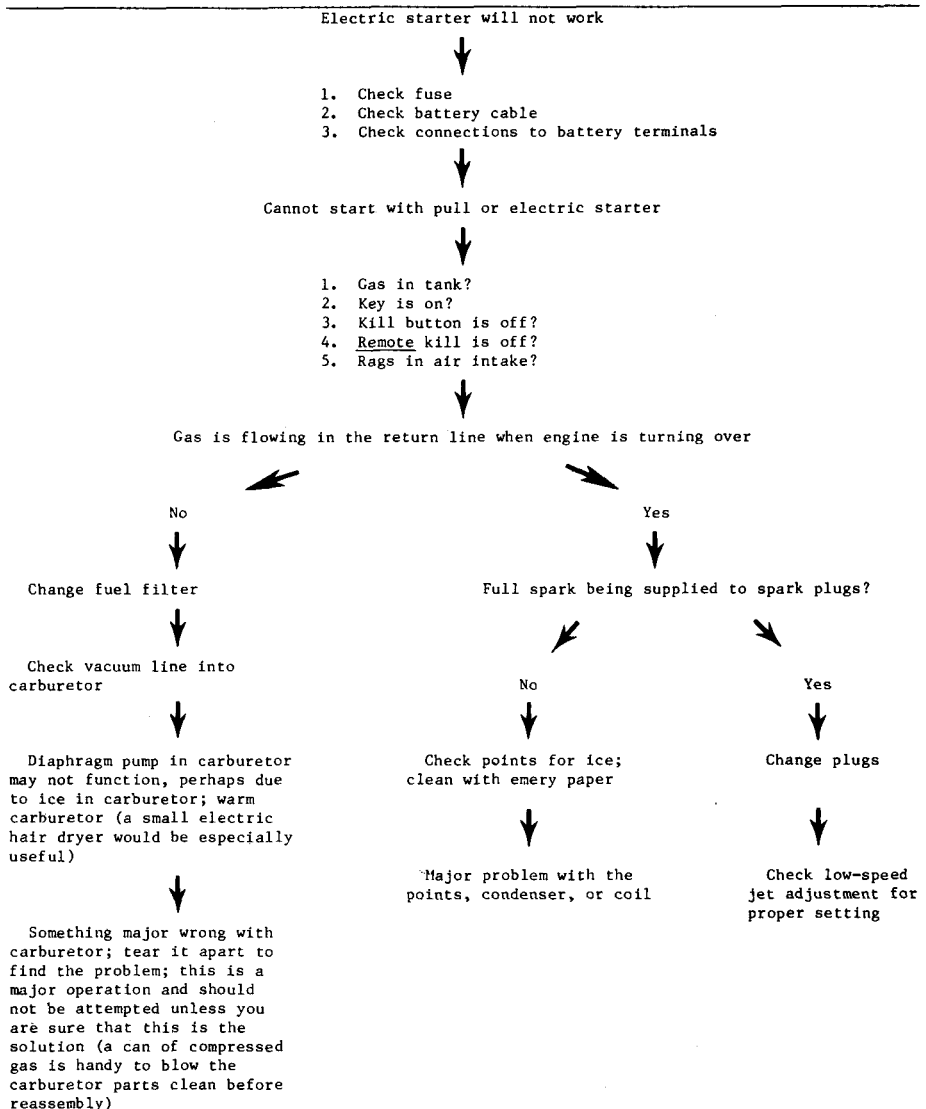

FIG. 5. Flow chart showing procedure for isolating starting problems.

## TROUBLE SHOOTING

During the field season we developed a routine of trouble shooting that isolated and corrected problems rapidly. This procedure is shown in Figure 5. Most problems were due to fouled spark plugs or clogged gas-line filters. These were checked first when we noticed power-loss or starting problems. It was found that replacing spark plugs or gas-line filters corrected a problem even when plugs or filters looked normal. We therefore recommend carrying many spare plugs and filters and that the fuel filter on the bottom of the carburetor be replaced by an adapter so that in-line fuel filters, which are easier to check or replace, can be used.

If the Ski-Doo shows loss of power while running, replace spark plugs. If it runs for awhile, then stops, the problem may be due to a vacuum in the gas tank, caused by a clogged breather line. This may be verified by unscrewing the gas cap immediately after stopping while listening for air rushing into the gas tank. If the air-line is not the problem, then check for a plugged gas filter. Loss of power also could be due to a partial grounding of the kill switch; try disconnecting the kill switches by unplugging their junction box.

If the snowmobile still will not develop full power, check the carburetor jet adjustment, the fuel filters, and the drive belt. Alternatively, there may be too much oil in the gas. This can be checked by inspecting the spark plugs for oiliness; if they are oily, empty the gas tank and refill with properly mixed gas. If this is not the problem, the spark may be weak; alternatively, check to see if rags have inadvertently been left in the air intake. If it is difficult to get the snowmobile moving even though the engine is working properly, the driven pulley may not be returning to the low-gear position. Correct the problem by cleaning the pulley by putting light-weight oil on the shaft and wiping the shaft with a soft rag. Work the driven pulley back and forth during cleaning.

If the engine is running well but the ride is rough, check the bogie wheels. They occasionally will flip over during travel on rough surfaces, especially if the track is loose. Bogie wheel assemblies also may break, and so spares should be taken.

## CONCLUSIONS AND RECOMMENDATIONS

Using the techniques described here, the snowmobiles ran well. One Ski-Doo was abandoned due to a broken drive shaft. This problem has occurred with other field parties and a spare drive shaft should be included in the spare parts kit. An important factor influencing snowmobile performance is the driver with those persons who do not treat the vehicle properly finding it in constant need of maintenance.

The following suggestions might improve usefulness and performance of Ski-Doos in Antarctica: 1) every snowmobile should be equipped with a tachometer, speedometer, and odometer; these accessories would be especially valuable for travel during low-visibility conditions; 2) all vehicles should be equipped with the low-gear option; 3) new vehicle transmissions

should be modified so that they have a neutral position; 4) the fuel filters on the bottom of the carburetor should be replaced with in-line filters at the gas tank as in-line filters are more convenient to change in the field; 5) Ski-Doos for field parties should be equipped with Seagull throttle controls; 6) all persons who plan to operate snowmobiles should attend a short course taught by the mechanics at McMurdo Station; 7) remote field parties should be given snowmobiles that have been used no more than two previous seasons; and 8) steps should be taken to prevent the misuse and abuse of the snowmobiles by unauthorized personnel during the time the Ski Doos are not being used by the field parties.

#### ACKNOWLEDGEMENTS

The Orville Coast project was supported by National Science Foundation Grant DPP76-12557. The U.S. Navy VXE-6 provided aircraft support. Holmes and Narver, Inc. and the other arms of the U.S. Navy provided additional logistic support. We thank the other members of the field party, consisting of Geologists P. E. Carrara and K. S. Kellogg of the U.S. Geological Survey; T. S. Laudon of the University of Wisconsin-Oshkosh; M. R. A. Thomson of the British Antarctic Survey; and W. R. Vennum of California State College-Sonoma; and U.S. Geological Survey topographic engineers D. E. Reed, E. G. Schirmacher (topographer in charge), and H. L. Zohn. We are grateful for the assistance given by D. P. Holloway (Holmes and Narver, Inc.), chief mechanic at McMurdo Station who supervised preparation of the vehicles. We also thank Duane Ness, J. L. Chambers, and S. J. Lasorsa of Holmes and Narver, Inc. for their help in preparing field vehicles. W. H. Nelson and A. B. Ford of the U.S. Geological Survey and Skip Green of Rocky Mountain Rescue Group, Boulder, Colorado, had many recommendations for snowmobile modifications. P. E. Carrara and W. H. Nelson reviewed the manuscript.

#### REFERENCES

- BOYER, S. J., ROWLEY, P. D., and KELLOGG, K. S. 1976. Camping and trail methods used on the Lassiter Coast, Antarctica: *Summit*, 22 (4): 8-11, 36-39.
- SOHOLT, D. E. and CRADDOCK, CAMPBELL. 1964. Motor toboggan sled trains in Antarctica: *Arctic*, 17 (2): 99-104.
- SWITHINBANK, CHARLES. 1962. Motor sledges in the Antarctic: *Polar Record*, 11 (72): 265-269.